



IRVWPC

INTELLIGENT RV WATER
PUMP CONTROLLER

Installation and Operating Manual

Revised 03/17/2021

Email: irwpc@gmail.com

IRVWPC Packing list

Quantity	Description
1	IRVWPC Controller Module
1	Pressure sensor fitting street elbow assebly
1	1/2" x 1/2" MPT male/male coupling
1	12" stainless braided 1/2"x 1/2" FPT flex hose
1	Right Angle adapter (90 degree swivel elbow and straight male)
2	#8 x 5/8" pan head mounting screws
1	8" Wire Lead w/ 1/4" blade male Quick-connect
1	8" Wire Lead w/ 1/4" blade female Quick-connect
2	Wire-Nuts
1	10A Fuse

IRVWPC Wiring Alert

It has come to our attention that some RV manufacturers have NOT maintained correct polarity when connecting their RV power wires to the water pump. The RV water pump is not polarity dependent because of its piston design and if connected with opposite polarity, it will still function.

The IRVWPC electronics are polarity dependent and must be connected to the proper polarity to function. Connecting an IRVWPC to a power source with INCORRECT polarity, will NOT damage the unit but will blow one of the 10A fuses within.

We suggest that the installer inspect the wire color of the RV power wires prior to installation and verify the polarity if possible. The RV standard is to use a WHITE wire for the DC NEGATIVE, and OTHER colors for the DC POSITIVE. If the RV WHITE is found to be connected to the RED pump wire, then this situation must be corrected. The RV WHITE wire must connect to the BLACK on the IRVWPC unit and the RV POSITIVE (could be black, orange, yellow etc.), must connect to the RED pump wire.

RED is positive and BLACK is negative on the IRVWPC.

Pressure Sensor Handling Alert

Pressure Sensor Handling Alert

The pressure sensor has been factory sealed into the plastic elbow fitting and pressure tested. **DO NOT turn the pressure sensor by hand or by wrench. Turning of the sensor can break this factory seal, resulting in water leaks.** Only tighten the assembly by force on the plastic elbow fitting.

Right Angle Adapter Installation Alert

When installing the MALE threads of the right angle adapter into the female side of the pressure sensor elbow, it MUST only be tightened by hand, with some potable water as a lubricant on the internal white cone and no more than 1/2 of a turn once contact is felt

between the 2 components. Over tightening can result in dislodging the internal sealing cone within the pressure sensor elbow.

The danger of dislodging the cone seal will only occur if these components are disassembled. Therefore, once together, leave it together.

Should the PEX fitting need to be adjusted for positioning, hold the black male fitting with a small adjustable wrench or pliers.

Contact us at: irvwpc@gmail.com with any questions.

Live chat is also possible through our website: www.irvwpc.com

Table of Contents

1.0 Overview	5
1.1 LED Indicators	6
2.0 Installation	7
2.1 Initial Installation Procedure	8
2.2 Pressure Sensor Installation	8
2.3 Controller Installation	9
2.4 Installation Check Points	11
3.0 Start-up	11
4.0 User Adjustments	13
5.0 Troubleshooting	18
6.0 Controller Specifications & Schematic	19
7.0 General Limited Warranty	20

1.0 Overview

The typical RV water pump operates in a fully ON or OFF cycle, where water flow is controlled by a pressure switch that stops the pump at a maximum pressure and an internal by-pass that allows water to recirculate back to the pump inlet. While this mechanical system to regulate the pressure works, it is inherently inefficient, noise due to intermittent ON and OFF operation (a complaint heard by many RV owners) and can lead to premature failure in the water system components caused by undue mechanical stress.

The IRVWPC is an electronic module that works with a water pressure transducer to prevent RV water pumps from operating in by-pass and cycling modes resulting in improved electrical efficiency, quiet operation along with a consistent regulated water pressure and steady water flow without the use of an additional accumulator tank. The IRVWPC eliminates the required mechanical adjustments found on these pumps.

The IRVWPC uses a dedicated control algorithm designed to regulate the speed of the pump to only operate as required to reach the desired water flowrate. Very low flowrates can now be achieved without the typical pump cycling ON and OFF or the pump operating in by-pass mode. The original pump controls remain functional and can be used as back up to operate the pump. This module is ideally suited for RV Boon-dockers who are constantly trying to conserve battery power and water resources. The regulated pressure which results in steady water flows aids On-Demand hot water heaters in providing a constant regulated water temperature.

Installation is simple and can be performed by the RV dealer or a Licenced RV Technician. Unit comes with the pressure transducer adapter fitting, a right-angle fitting section and a 12" stainless braided hose section for easy connection to the water pump's outlet port and 3 power wires for connection to the pump motor. A male and female power tap connector for the 12V positive connection and Quick-

Connect blade style connectors to break the connection on the pump motor negative wire.

All non-metallic water system components have NSF61 approval for potable water and the pressure transducer is 100% 304/316L stainless steel.

Typical installation can be performed in less than 15 minutes.

1.1 LED Indicators

FAULT (RED) - This indicator represents 5 different fault conditions that can occur. There is a solid ON state and 4 blinking states. These are detailed below:

- A solid RED indicates a pressure sensor fault, a disconnected sensor or an internal sensor failure. The controller will respond to a **FULL-ON** state indicated by the MAX LED being solid ON.
- 7 blinks or flashes followed by 4 seconds OFF indicates a DRY RUN TIMER Fault state. This fault condition will lock-out the pump and require the RV pump power switch to be turned OFF and then back ON to resume normal operation. A detailed description of the DRY RUN can be found in the PUMP SAFE-GUARD options section.
- 6 blinks or flashes followed by 4 seconds OFF indicates a LONG RUN TIMER Fault state. This fault condition will lock-out the pump and require the RV pump power switch to be turned OFF and then back ON to resume normal operation. A detailed description of the LONG RUN can be found in the PUMP SAFE-GUARD options section.
- 5 blinks or flashes followed by 4 seconds OFF indicates a LOW FLOW CYCLING Fault state. This fault condition will lock-out the pump and require the RV pump power switch to be turned OFF and then back ON to resume normal operation. A detailed description of the LOW FLOW CYCLING can be found in the PUMP SAFE-GUARD options section.
- 4 blinks or flashes followed by 4 seconds OFF indicates a RUN WATCHDOG Fault state. This fault condition will lock-out the pump and require the RV pump power switch to be turned OFF and then back ON to resume normal operation. A detailed description of the RUN WATCHDOG can be found in the PUMP SAFE-GUARD options section.

RUN (GREEN) - This indicator continuously blinks at a steady ½ second ON and ½ second ON rate when POWER is applied to the control unit and the PUMP state is **IDLE**. When the

PUMP is **RUNNING** at a speed or flow rate above what is considered normal operation, this RUN indicator will be constantly ON.

PRESS (**GREEN**) - This indicator represents 2 different states.

- Under normal running operation this LED will flicker ON/OFF during the condition where the control is actively adjusting to the pressure setting. It is very normal to see fast flickers with no real pattern.
- When the water flow is stopped (all faucets closed), this LED will be solid ON. This is a holding pressure condition when the pump has stopped.

MAX (**RED**) - This indicator represents when the control is a maximum output. This is FULL ON, supplying full voltage to the pump motor. This occurs on large water flow volumes where the pump is not capable of supplying enough water to achieve the pressure setting. This is the point where the control can no longer regulate the pressure to the desired setting.

Any of the FAULT conditions are easily RESET by simply turning your pump power switch OFF and back ON again.

2.0 Installation

WARNING: Installation should be performed by a qualified Licensed RV Technician. Failure to do so can result in damaged components or water damage to your RV.

CAUTION: Installation fittings seal with an internal taper and the use of Sealers and Teflon tape are not required, as it may cause stripped threads or cracked fittings due to over-tightening. All fittings are recommended to be firmly HAND tightened only.

After installation the system MUST be pressure tested to ensure no leaks and frequent inspection is recommended to ensure no possible water damage.

The existing piping SHOULD NOT be placed under any stress in order to make the connections. This could cause a cracked or damaged pump housing resulting in water damage and/or pump failure.

IMPORTANT: Following any modification of the plumbing system, proper sanitization of plumbing

components **MUST** be performed. Failure to do so can result in serious personal health conditions. Refer to your vehicles manuals for the proper sanitization recommendations for the plumbing system.

2.1 Initial Installation Procedure

It is recommended that the installer follow all these directions and steps to aid in an easy trouble-free installation.

- 1) Turn OFF Hot water heater.
- 2) Remove DC power from the pump. This can be either by turning the pump control switch OFF, by turning the RV Master disconnect OFF or removing the pump fuse.
- 3) Remove pressure from the water system by opening a faucet.
- 4) Remove all water from the system by opening the low-point drains as would be done in the WINTERIZING procedure. This will prevent excess water leakage when disconnecting the pump outlet line.
- 5) Have towels/paper towel and possibly a suitable pan or bowl to aid in catching any leaking water during the fitting removal process. This will guard against any water damage.

2.2 Pressure Sensor Installation

The pressure sensor is mounted into a modified ZURN Quick-Tite street elbow fitting allowing it to be directly mounted to the pump outlet provided that the existing plumbing hose or piping can be rotated / adjusted to be reconnected to the male threads on the elbow. Mounting the sensor directly to the pump might not work in some situations, the proper positioning of the male threaded end may not be possible to achieve and over-tightening may result causing pump or elbow damage. In these situations, either the hose or right-angle adapter must be used. These have a swivel ends and allow infinite positioning.

If space does not permit, such as the pump outlet very close to a wall, then the use of the right-angle adapter will work well in this case. The orientation of the right-angle adapter can be adjusted by rotating the PEX fittings within the PEX pipe section. By firmly holding and rotating the fittings any alignment can be achieved.

Some RVs use a flexible hose on the pumps discharge and it is likely that this can be readjusted in position to reconnect. If this is not possible, then by attaching the supplied braided hose and coupling fitting, it should be possible to achieve an unstressed connection back to the original piping in most applications.

All loose pipes or hoses should be securely fastened with Zip-Ties or plastic pipe clamps to minimize vibrational noise that could be created from piping modifications.

WARNING - *DO NOT rotate the pressure sensor. It has been factory sealed and tested for leaks. Rotating the sensor can break this seal resulting in a water leak!*

- **Do not stress the piping in any way in an attempt to make the connection. PEX piping cannot be sharply bent or kinked.**
- **Do not over-tighten fittings in an attempt to achieve better positioning. It is better to use the extra braided extension hose than to stress fittings to the breaking point.**

2.3 Controller Installation

The IRVWPC electronic controller is housed in a Polycarbonate Flammability Rated Industrial enclosure. The enclosure is water resistant but not waterproof. A suitable mounting location should be chosen. Mounting is limited by the length of the sensor cable (15") and the pump motor electrical wires (16") but this will easily satisfy most installations. The enclosure has mounting tabs that are pre-drilled, using two #8 wood screws will provide plenty of mechanical rigidity. The transparent cover allows visual observation of the four LED indicators and the unit should be mounted in a visible location.

It is recommended that the pressure sensor be left unconnected until the water system has been purged from all air introduced during system draining and installation procedures.

The supplied pressure transducer uses an Automotive style water-resistant connector and is mechanically keyed to prevent improper installation. To install the connector, align the locking tab slot with the tab on the sensor body and apply firm pressure to properly latch and seat the connector. A positive CLICK can be heard when the connector latch is engaged.

The use of different width Quick-Connect TAB connectors and genders ensures all connections have proper polarity and are correctly connected to their respective wires. It is recommended that the user retain these connectors with proper gender during installation. Should these wires need to be lengthened only the three 16 AWG wires can be modified. Proper soldered joints or crimp connectors should be used and sealed. Failure to make good quality connections can result in improper operation or failure.

A RED (positive) wire connects to the nose of the pump. This wire comes from the RV wiring power source. Remove this Quick-Connect Blade Style connector by firmly pulling down. Once removed, this connector can be inserted into the mating BLUE shrouded male Blade connector with the double RED lead wires. These Quick-Connect Blade connectors have a specific width blade and will only fit to the intended match. The other BLUE Blade female connector with a heat-shrink extension can be now connected to the nose of the pump where the original RV supply wire was previously removed. This connection effectively taps into the 12VDC power while still retaining the pressure switch internally in the pump.

The original pump motor BLACK (negative) must now be cut and connected to the PURPLE controller wire. This wire from the controller has a BLUE ¼" shrouded male Quick-Connect Blade connector and will connect to the pump motor lead using the supplied Wire-Nut and the PURPLE 8" length of lead wire with a mating female ¼" Blade connector (wire can be shortened if required). Wires should be stripped 3/8" for proper function of the Wire-Nut. A visible 1 turn twist in the lead wires ensures proper tightening. A few wraps of electrical tape should also be used to ensure the Wire-Nut cannot back OFF. **See pictures on the next page for Wire-Nut tightening and taping.** Alternatively, this connection could be soldered or if a proper crimping tool is available, the supplied connector can be crimped directly on the pump wire, not using the factory crimped wire assembly.

The remaining wire which is the negative connection to the RV's power source is to be now connected to the BLACK controller wire. This BLACK wire has a BLUE ¼" female Quick-Connect Blade connector and will connect to the RV using the supplied Wire-Nut and the Black length of lead wire with the mating ¼" male Blade connector. Use the same procedure for the Wire-Nut, soldered connection or crimped as described in the above paragraph.

Opposite gender connectors allow the controller to be simply unplugged and the pump can be quickly reconnected by simply joining the connectors back together providing a quick bypass to original operation should the controller fail for any reason.

These connectors allow the Controller to be completely removed if desired for the sale of the RV. These ¼" Quick-Connect Blade connectors can be found in most Automotive parts stores.



Proper Wire-Nut Tightening



Recommended Wire-Nut Taping

2.4 Installation Check Points

- 1) All piping connections are hand-tightened firmly and piping is secured and no stress or strain is on any piping or pump fittings.
- 2) All electrical connections are properly connected with Wire-Nuts taped.
- 3) Controller is securely mechanically mounted.
- 4) Low point drains are properly closed.
- 5) Bleach solution added for Sanitization as per vehicle Manufacturer's recommendations.

3.0 Start-up

Initial Start-up Procedure:

- 1) Ensure the pressure sensor connector is disconnected. If not, gently lift the locking tab above the sensor body tab and gently pull the connector. **DO NOT PULL ON THE SENSOR WIRES.** You can push back against the tab to ease the connector back. The silicone rubber sealing ring internal to the connector causes some suction requiring moderate force but should come easily. If the connector cannot be removed to your comfort level, don't force it. The system can be started with the sensor connected but more erratic operation may occur until all air is purged.
- 2) Remove the PURPLE or BLUE wire from the pump motor lead by pulling the ¼" Quick-Connect Blade connector apart.
- 3) Restore the power to the pump circuit and observe the LED indicators. They should appear as follows:
 - A) FAULT (RED) should be ON, indicating that the sensor is disconnected. If the sensor is connected to the control then this LED will be OFF.
 - B) RUN (GREEN) should be blinking steady, ½ second ON, ½ second OFF. This indicates that the power is ON and the micro-controller is operating.
 - C) PRESS (GREEN) should be OFF.MAX (RED) should be ON. This indicates the controller is at MAXIMUM output. This is generated when a sensor failure is detected. It displays ON when the sensor is not detected by the controller.

- 4) Turn the RV pump controller switch OFF and reconnect the PURPLE or BLUE wire as was disconnected on STEP 2.
- 5) Turn the RV pump switch back ON. Now with the pump wire connected as above in Step 4 the pump will run as it typically did. Open a nearby faucet to purge all air for the pump. Once the pump settles down and appears to be running normally, turn the pump switch OFF and close the faucet.
- 6) Connect the pressure sensor wire, align the locking tab slot with the tab on the sensor body and apply firm pressure to properly latch and seat the connector. A positive CLICK can be heard when the connector latch is engaged.
- 7) Turn the pump switch back ON, the RUN LED should be SOLID and the Controller now will power the pump motor to the pressure set-point (Factory supplied setting is 32 PSI). The PRESS LED should come solidly ON. This indicates the Controller has achieved the SET pressure. When the IDLE (pump OFF) state is achieved, the RUN led will return to blinking.
- 8) Slowly open a nearby faucet at a low flow rate. Pump should immediately start and the once solid ON PRESS LED should be quickly flickering. This is normal operation. Increase the faucet flow and observe the LEDs, steady ON RUN and flickering PRESS. Open the faucet(s) to their full open position and other faucets until the MAX LED comes on. This is point where the Controller has reached maximum output and the pump is running at its full capacity.

This completes the procedure and Start-up procedure. Please refer to the troubleshooting section for common installation issues.

IMPORTANT: Sanitizing is required after installation of the pressure sensor and/or any modifications to the plumbing connections in the RV. You can check your Vehicle Owner's Manual for specific instructions. Failure to do so can result in serious personal health conditions.

4.0 User Adjustments

Pressure Setpoint

The controller comes preset from the factory on pressure setting #2 (~33 PSI). Should more or less water pressure be desired, this pressure can be user adjusted by following these steps:

- 1) Remove power to the unit by turning the RV PUMP switch OFF.
- 2) Loosen the 4 Phillips head cover retaining screws. These fasteners are retained within the cover and just have to be backed-off to the point where the cover can be lifted off. ***Be very careful with screwdrivers around the open unprotected circuit board. Surface mounted electronic components are very sensitive and are very easily damaged. Mechanically damaged components will void the warranty.***
- 3) Using a small flat blade screwdriver, rotate the pointer slot to the desired position. 0 is approximately 30 PSI with 9 being approximately 44 PSI. This is a rotary switch and has detent stop positions for each value.
- 4) Reinstall the cover and reapply power to the unit.

Pump Safe-Guards

The controller also provides timers and counters to protect against conditions that could impact the life of the RV pump and potentially protect against water damage from plumbing system failures. These SAFE-GUARDS cannot guarantee and protect 100% against pump and water system issues but can provide some comfort in potential protection.

- 1) Remove power to the unit by turning the RV PUMP switch OFF.

- 2) Loosen the 4 Phillips head cover retaining screws. These fasteners are retained within the cover and just have to be backed-off to the point where the cover can be lifted off. **Be very careful with screwdrivers around the open unprotected circuit board. Surface mounted electronic components are very sensitive and are very easily damaged. Mechanically damaged components will void the warranty.**
- 3) Using a toothpick, slide the small white actuators for the appropriate function toward the outside of the case for OFF, and toward the inside for ON..
- 4) Reinstall the cover and reapply power to the unit.

IRVWPC units have 4 pump and water system guarding options that can be enabled or disabled by slide switches 3,4,5, and 6. Some users may desire these options depending on certain use situations. There is no guarantee that these systems can provide 100% protection against all situations. They are provided to offer some peace-of-mind and frequent visual system inspection is always required to detect plumbing system issues or failures.

Switch #1 should be left untouched on the ON position, this is turned ON at the factory after programming is complete.

Switch #2 has no function.

NOTE: After programming is complete, return the slide switches to the positions required for the desired functions.

Dry Run Timer - Switch #6

The DRY RUN timer safe guards the water pump from running at full speed without any water in the system. This situation can be created by the user improperly positioning water tank fill valves and leaving the water pump turned ON by accident, running out of water or a plumbing system failure which causes the pump to run but not achieve the operating pressure. In a normal system the pump could run for hours if undetected by the user, resulting in over-heating and burning the pump out. Since the IRVWPC module is aware of the pump running and the system water pressure, this DRY RUN timer will immediately stop the pump if the running period exceeds the time setting and the low-pressure level. Factory default setting is 30 seconds of running with the system pressure less than 15 PSI. The control is shipped from the factory with this option feature turned ON. This shutdown alarm condition is indicated by 7 consecutive flashes of the FAULT LED followed by 4 second OFF period. This continuously repeats and a power OFF and back ON resets the fault.

Long Run Timer - Switch #5

The LONG RUN TIMER is a simple timer that measures the length of time that the pump control has been left on. Some users prefer to NOT have the pump operational at all times in their RV and would rather have the control automatically turn OFF. This timer can be adjusted from 10 to 100 minutes and is factory set at 60. The control is shipped from the factory with this option feature turned OFF.

This shutdown alarm condition is indicated by 6 consecutive flashes of the FAULT LED followed by 4 second OFF period. This continuously repeats and a power OFF and back ON resets the fault.

Low Flow Cycling Counter - Switch #4

The IRVWPC control has an ability to operate the pump at very low flow levels, even as low as a slow dripping condition. Operation at these low flow levels can generate heat within the control power electronics and the pump. This operation is considered to be not a practical use of water flow rate. During these low flow levels, the RUN LED will blink as it would with the control at idle and the PRESS LED can be seen to flash at longer periods versus normal running. The LOW FLOW CYCLING if turned ON will accumulate these low cycles and will stop the pump if this value exceeds the setting. These LOW FLOW CYCLES can occur during normal operation such as opening the faucet slowly or throttling the faucet down prior to closing. Once the pump achieves normal running (PRESS LED steady ON), the accumulated value is reset to zero. This allows the control to tolerate brief periods of low cycling but not continuous low cycling.

Factory default setting is 20 cycles. The control is shipped from the factory with this option feature turned ON. This shutdown alarm condition is indicated by 5 consecutive flashes of the FAULT LED followed by 4 second OFF period. This continuously repeats and a power OFF and back ON resets the fault.

Run Watchdog Timer - Switch #3

The RUN WATCHDOG TIMER is a timer that measures the length of time that the pump control has been running at the pressure setting, indicated by the RUN LED steady ON. This timer is useful to limit the ON or USE period. It also can be used to protect against plumbing system failures. This timer is reset to zero once the control comes back to an idle state with the pump off. It only accumulates continuous running and is reset to zero at idle. If users choose to use this feature, ensure that the time setting exceeds your continuous showering period, nothing worse than no water in the shower. For example, if the shower is used for a 30 second wet-down, then turned off, the accumulated value is reset. Even if this timer is set as low as 60 seconds, if the pump stops or idles before this 60 second example, the pump starts with a fresh time period.

This timer can be set from 10 to 1000 seconds in multiples of 10 seconds. For 60 seconds, a value of 6 is entered for six 10 second periods plus the minimum time of 10 seconds.

The control is shipped from the factory with this option feature turned OFF and a setting of 300 seconds.

This shutdown alarm condition is indicated by 4 consecutive flashes of the FAULT LED followed by 4 second OFF period. This continuously repeats and a power OFF and back ON resets the fault.

Programmable Settings

IRVWPC units have slide switches and a momentary push button switch to allow the user to customize settings related to these features. Also, some of the running parameters can be tuned to a specific application. A RESTORE TO FACTORY DEFAULTS can also be executed to return all user adjustable settings to their original values.

PROGRAM mode is entered from the RUNNING mode by holding the PUSH BUTTON for a constant 10 seconds, the RUN and PRESS LEDs will alternately blink back and forth to indicate when to release the BUTTON. This blinking pattern will continue for 15 seconds. The RUN LED will be in the fast blink pattern when the unit is ready to be programmed.

A total of 15 permanent memory locations can be accessed and reprogrammed from the supplied factory settings. The first 4 settings are related to the safe guard features and the user should only change these settings. The other settings should ONLY be preformed from direct consultation with the factory or a representative. Improper adjustment of these settings can affect proper control operation of the pump and possible damage to the pump.

The programming feature is easy to use, the rotary selector (0-9) is used as the variable input, slide switches 3,4,5 and 6 are used to select the memory location and the push button enters the value to memory. New data is accepted by momentarily pressing the PUSH

BUTTON, the RUN and PRESS LEDs will blink in an alternate pattern and the PRGM/MAX LED will light solid. After 10 blink cycles the pattern will stop and the RED PRGM/MAX LED will go out. This is the completion of the program process for that specific memory location.

Some locations require a 2-step process for greater resolution or a larger range of adjustment for the parameter. This process is similar, slide switches select the specific location, rotary selector position generates a value for the first part of the variable and the second step generates an input for the last part. These are multiplied and summed, resulting in a larger input variable. Different variables have different calculations, so refer to the following table for the appropriate calculations.

Upon pressing the PUSH BUTTON for the most significant value, the LEDs will behave as they do for a single-step input, but the PRESS LED will remain ON, indicating that the first part of the process is complete and now the least significant portion must be completed. Once the least significant portion is completed, all LEDs will turn off, leaving the fast blinking RUN.

Some variables are restricted to a certain range and others start with an offset. The table below shows the variables and their value ranges.

RESTORING TO FACTORY is a simple process of setting all 4 slide switches (3,4,5, 6) to the ON position and pressing the PUSH BUTTON.

To return the control to normal operation remove power to the unit and then back ON again. The control will start in the normal operating mode. Set switches 3,4,5 and 6 back to the desired functions. The normal 1 second IDLE blink rate of the RUN LED will return.

NOTE: A SMALL NON-METALIC SCREWDRIVER OR TOOTH-PICK SHOULD ONLY BE USED TO ACTUATE THE SLIDE SWITCHES.

Programmable Settings Table

	SW3	SW4	SW5	SW6	Function	Setting Calculation	Default
1	OFF	OFF	OFF	OFF	Dry run timer period (seconds)	10-100 range $((0-9)+1) \times 10$	20
2	ON	OFF	OFF	OFF	Long run timer period (minutes)	10-100 range $((0-9)+1) \times 10$	60
3	OFF	ON	OFF	OFF	Low flow cycling counter	10-100 range $((0-9)+1) \times 10$	20
4	ON	ON	OFF	OFF	Run watchdog - # of 10 sec periods	1-100 range $(0-9) \times 10 + (0-9) + 1$	29
5	OFF	OFF	ON	OFF	Reserved		1

6	ON	OFF	ON	OFF	Reserved		1
7	OFF	ON	ON	OFF	Reserved		1
8	ON	ON	ON	OFF	Pressure level for dry run	$((0-6) \times 10) + 30$	80
9	OFF	OFF	OFF	ON	PWM level for pump run determination	$((0-9) \times 5) + 70$	90
10	ON	OFF	OFF	ON	Upper DB constant	$(0-9) + 1$	3
11	OFF	ON	OFF	ON	Lower DB constant	$((0-9) \times 2) + 2$	10
12	ON	ON	OFF	ON	Lower DB multiplier	$(0-5)$	4
13	OFF	OFF	ON	ON	Kp PID value	$((0-9) \times 10) + (0-9) + 5$	10
14	ON	OFF	ON	ON	Ki PID value	$((0-9) \times 10) + (0-9) + 50$	90
15	OFF	ON	ON	ON	Kd PID value	$((0-9) \times 10) + (0-9) + 10$	20
16	ON	ON	ON	ON	RESTORE TO FACTORY DEFAULTS		

NOTE: After programming is complete, return the slide switches to the positions required for the desired functions.

5.0 Troubleshooting

FAQ's:

Q: Pump appears to cycle quickly as it did before the Controller installation on low water flows?

A: Verify no FAULT LED, ½ second blink rate of the RUN LED and a steady ON wjth the pump running, the fast flicker of the PRESS LED, and no MAX LED. It is possible that the pump pressure switch has been previously adjusted in an attempt to smooth the pump. It is important that this pressure setting be restored close to the factory setting (~45 PSI). Please refer to the pump manual for adjustment of this pressure setting.

Q: I'm in the process of pumping RV antifreeze solution for Winterizing and the pump suddenly stops?

A: This most likely was the DRY RUN PROTECT feature and it stopped the pump due to a pressure loss for more than the set time. Simply, turn the pump switch OFF, and then back

ON. This will RESET the lock-out feature and the pump will restart. This cycle may occur a few times during Winterizing but will not damage anything. It is a safety feature.

Q: I've filled my Potable water holding tank and the pump stops while trying to prime the system with water?

A: This most likely was the DRY RUN PROTECT feature and it stopped the pump due to a pressure loss for more than the set time. Most systems should prime within 30 seconds. Reset the power by turning the Pump switch OFF, then back ON. The Pump will restart. If the system will still not prime and this protection feature keeps turning the Pump OFF, it is likely that some other problem in the system is preventing the prime. Refer to your vehicles manual for possible solutions.

Immediately after resetting the power observe the FAULT LED, if the pressure sensor is connected and this LED is ON, there could be a sensor fault / failure.

Q: After installation the pump still is noisy on low water flows.

A: It is very possible that the inlet water screen is clogged material. Refer to your RV on removal and cleaning of this screen.

Customers may also email irvwpc@gmail.com with any questions.

6.0 Controller Specifications

Operating voltage: 10-15 VDC

Operating temperature: -40°C to 125°C

Switching current: MAX 10A (intermittent operation)

Electronics current consumption: 19mA @ 12VDC with reverse polarity protection

High current switch protection: 10A 32VDC Automotive type ATOF/ATC fuses

Low current protection: 50mA automatic resettable fuse (not user serviceable)

Enclosure: POLYCARBONATE UL94-HB Flammability rated with mounting tabs

Status LEDs: FAULT, RUN, at PRESSure, MAXimum output achieved

Pressure setting range: Approximately 30 to 42 PSI in 10 adjustable steps

Dimensions: 14.5cm(5.75") x 6.5cm(2.6") x 4cm(1.6") (includes mounting tabs)

Agency approvals: Pending

Pressure Sensor Specifications:

Rugged, 100% stainless steel construction, 304/316L Fully Welded

Operating temperature: -40°C to 125°C

Total Error Band up to ±1 %FSS(-40°C to 125°C)

Over voltage protection ±40 Vdc

Mounting: ZURN QCE33TF Quick-Tite ½" MPT Street elbow, NSF61 approval

Wiring Schematic

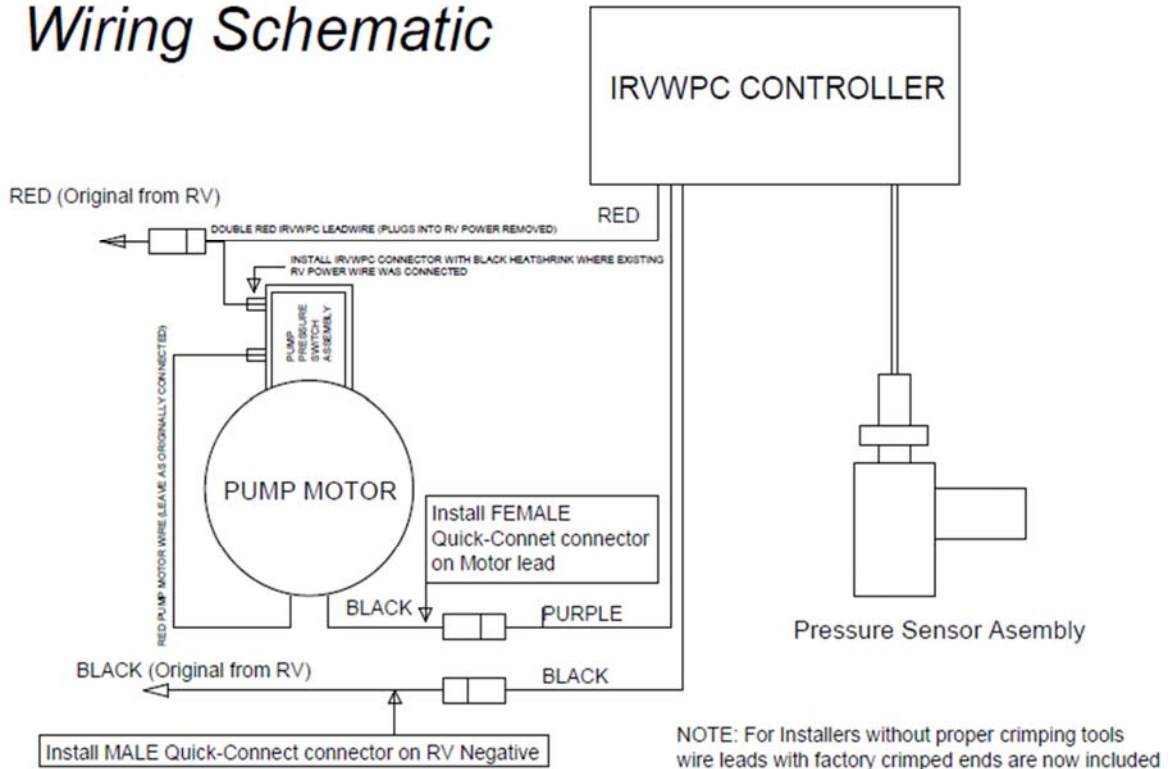

Figure 1: Wiring Schematic

7.0 Winterization

The Winterization procedure for the RV will be the same as without the IRVWPC controller. We recommend that RV Antifreeze be pumped into the system after all the water is drained. Blow-out methods do work for short term protection, but it is important that Antifreeze get into the pump chambers and pressure sensor. Blow-out can be used for emergency situations, but the water pump and the sensor should be kept above freezing. The surface tension of water droplets can allow water to remain trapped within the sensor and the only sure way to prevent potential sensor damage is either pump Antifreeze or keep the sensor above freezing.

8.0 General Limited Warranty

Sylva Control Systems Inc. warrants that the product described in this Installation and Operating Manual performs according to the features and specifications stated at the point of shipment and that it will be free of defects on materials and workmanship under normal conditions and use. This warranty becomes effective at the time of purchase of the product and remains in effect for a period of 12 months thereafter.

The obligation under this warranty is limited to the repair or replacement of defective parts, components or firmware at the option of Sylva Control Systems Inc. Shipping charges and onsite services if required, are not covered by the warranty and shall be to the customer's account.

Warranty is void if repairs are made by unauthorized third parties.

In no event shall Sylva Control Systems Inc. and/or any of its representatives be liable for consequential damages arising out of the ownership, installation and use of the product.